

TAKE THE NEXT STEP.

Complete the checklist below and contact Family Justice to develop a plan and move forward.

How can Family Justice help you and your partners incorporate a strength-based, family-focused approach in prevention and intervention efforts?

CHECK ALL THAT APPLY:

- Strategic planning
- Feasibility plan
- General overview and staff training
- Customized staff-development training
- Review of procedures, practices, and intake assessment forms
- Access to innovative tools, such as the Interrelational Database, the Membership Network, and the Relational Inquiry Tool
- Other _____
(Please specify.)

Please see reverse side.



625 Broadway, 8th Floor

New York, New York 10012

T 212.475.1500 **F** 212.475.2322

www.familyjustice.org

FAMILIES ARE PART OF THE SOLUTION



**THE
FAMILY JUSTICE
APPROACH**

**TAPPING FAMILIES AND SOCIAL NETWORKS
TO ENHANCE YOUR SERVICES**

FAMILY JUSTICE'S MISSION

Family Justice taps the natural resources of families, the collective wisdom of communities, and the expertise of government to make families healthier and neighborhoods safer. Since its founding in 1996, Family Justice has emerged as a leading national nonprofit institution dedicated to developing innovative, cost-effective solutions that benefit people at greatest risk of cycling in and out of the criminal justice system.

Through advocacy, education, and research, Family Justice offers a range of systemic interventions that address complex issues of people living in poverty, such as substance abuse, mental illness, and HIV/AIDS. By providing extensive training and support to government agencies and community-based organizations, Family Justice helps families to unlock their potential to lead healthier and more productive lives.

The Family Justice approach can help your organization meet its goals and maximize its effectiveness. We can teach your agency to tap the resources of social networks to improve the health and well-being of individuals and families and the safety of neighborhoods. Emphasizing prevention as well as intervention, our cost-effective approach can be easily adapted to complement and enhance your work.

RESEARCH SHOWS THAT THE FAMILY JUSTICE APPROACH

WORKS. An evaluation by the Vera Institute of Justice showed that Family Justice's strength-based approach to family case management helps reduce drug use and the rate of arrest among participants and improves the overall well-being of families living in poverty.¹ Those findings are consistent with other research demonstrating that strong family support helps people succeed after they leave prison or jail.^{2,3,4}

Family Justice develops creative initiatives with a wide range of strategic partners, including government agencies and community- and faith-based organizations in fields such as:

- Treatment and prevention of substance abuse, mental health, HIV/AIDS, and other chronic health conditions
- Criminal justice and juvenile justice
- Gang prevention and intervention
- Public housing, public health, and child welfare

SOCIAL NETWORKS MAKE A DIFFERENCE.

Whether your agency works with people who are involved in the criminal justice system or those at risk of such involvement, strong family support has a significant impact. When someone is arrested, incarcerated, on probation, or on parole, the effect on a family is dramatic. A social-support network can make a critical difference.

CRIMINAL JUSTICE ISSUES ARE PUBLIC HEALTH ISSUES. Families living in poverty frequently face severe and often multigenerational health concerns, some of which contribute to involvement in the justice system. A majority of people who are incarcerated deal with substance abuse issues, mental illness, or both. We help organizations work with families facing overlapping health issues and involvement in the criminal justice system or risk of such involvement.

CHART A NEW COURSE. Family Justice has the expertise and experience to assist government and nongovernmental agencies in changing their organizational culture. Throughout the country, people are integrating our approach into their work with positive results.

FAMILY JUSTICE PROVIDES TOOLS AND METHODS THAT WORK.

Teaching people that families are part of the solution, Family Justice trains professionals and paraprofessionals about its signature method, The Bodega Model®. An evaluation showed that among people who participated in our form of family case management, 90% resolved their medical-service needs and 80% resolved social-service needs within six months.⁵ Our approach considers each person's context, culture, and connections; builds on the interactions within social networks; and draws on the strengths of individuals, families, and communities.

Select the services your organization needs—and we will customize a plan. Family Justice provides five main services to government and nongovernmental organizations that would like to incorporate a strength-based, family-focused approach:

- **We provide strategic planning services** so that your agency can adopt cost-effective tools and methods that make families part of the solution.
- **We can work with your organization to create a feasibility plan** and customize an initiative that complements your work—at low cost or none.
- **We produce and conduct tailored training of management and other staff** to adapt a strength-based, family-focused approach to your work.
- **We provide evaluation and assessment services,** including review of your forms, policies, and practices, and measurement of the ongoing impact that your family-focused work has.
- **We provide access to a national membership network, a database that tracks individual and family outcomes, and other methods and tools** that keep you up to date on the latest advocacy, research, and policy issues.

OVERVIEW OF FAMILY JUSTICE TOOLS AND METHODS

For more than a decade at our first direct-service program, La Bodega de la Familia, we have developed and refined strength-based methods and tools for working with families. Family case management is at the heart of La Bodega's work. However, agencies that don't offer case management can adapt and apply the principles and tools of the Bodega Model.

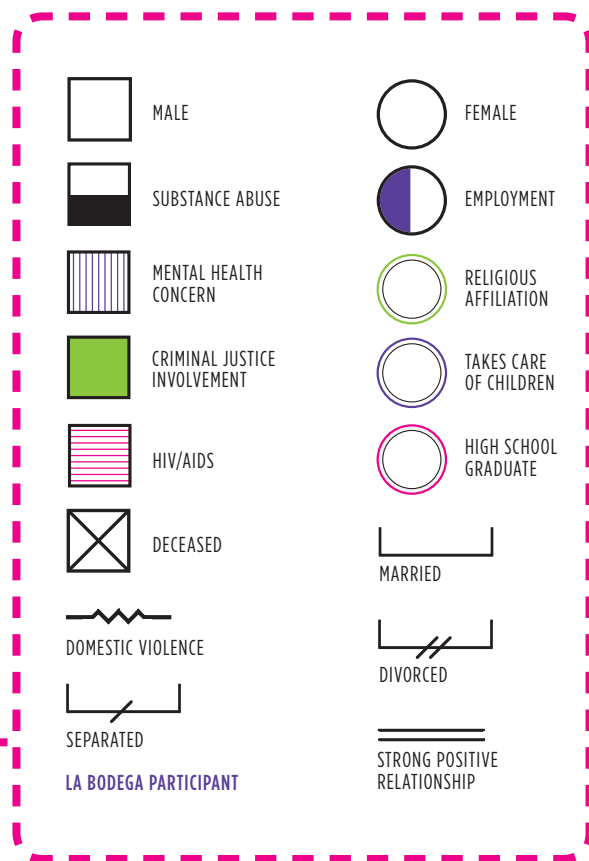
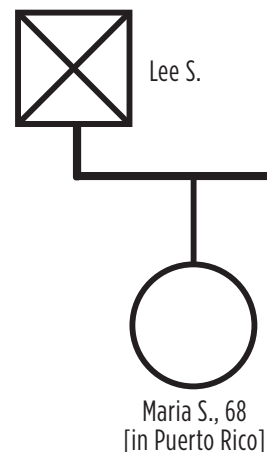

A **GENOGRAM** is a tool that goes beyond the typical family tree, recording strengths and challenges such as education, employment, criminal justice or juvenile justice involvement, substance abuse, mental health issues, and chronic illnesses.

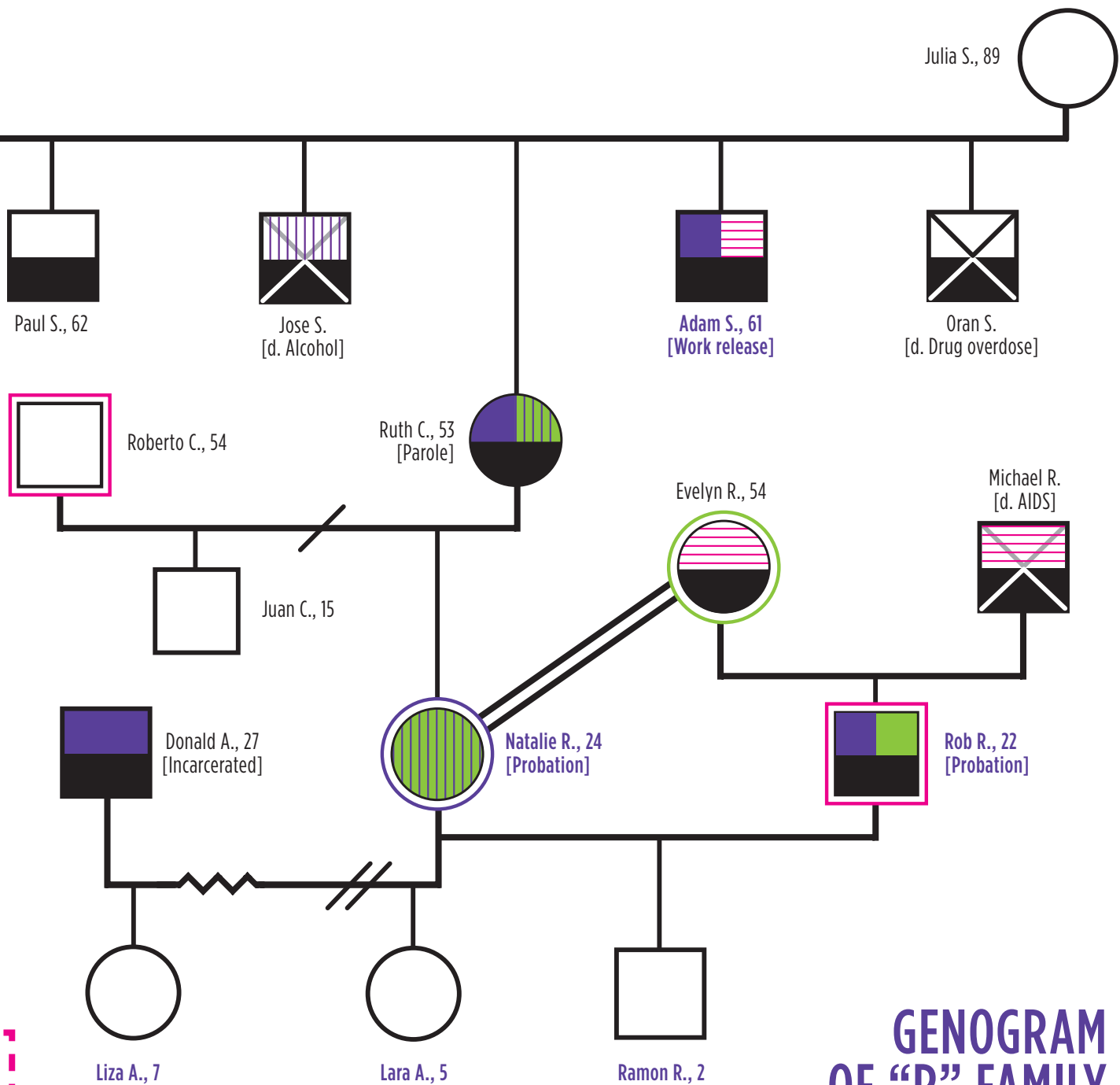

GENOGRAM OF "R" FAMILY

An **ECOMAP** illustrates the relationships between family members and the key people and institutions in their lives. These may include schools, houses of worship, employers, probation or parole officers, child welfare, drug counselors, health-care and child-care providers, and social workers. The ecomap also depicts the nature of the relationship between agencies, allowing insight about ways to improve communication and service coordination.

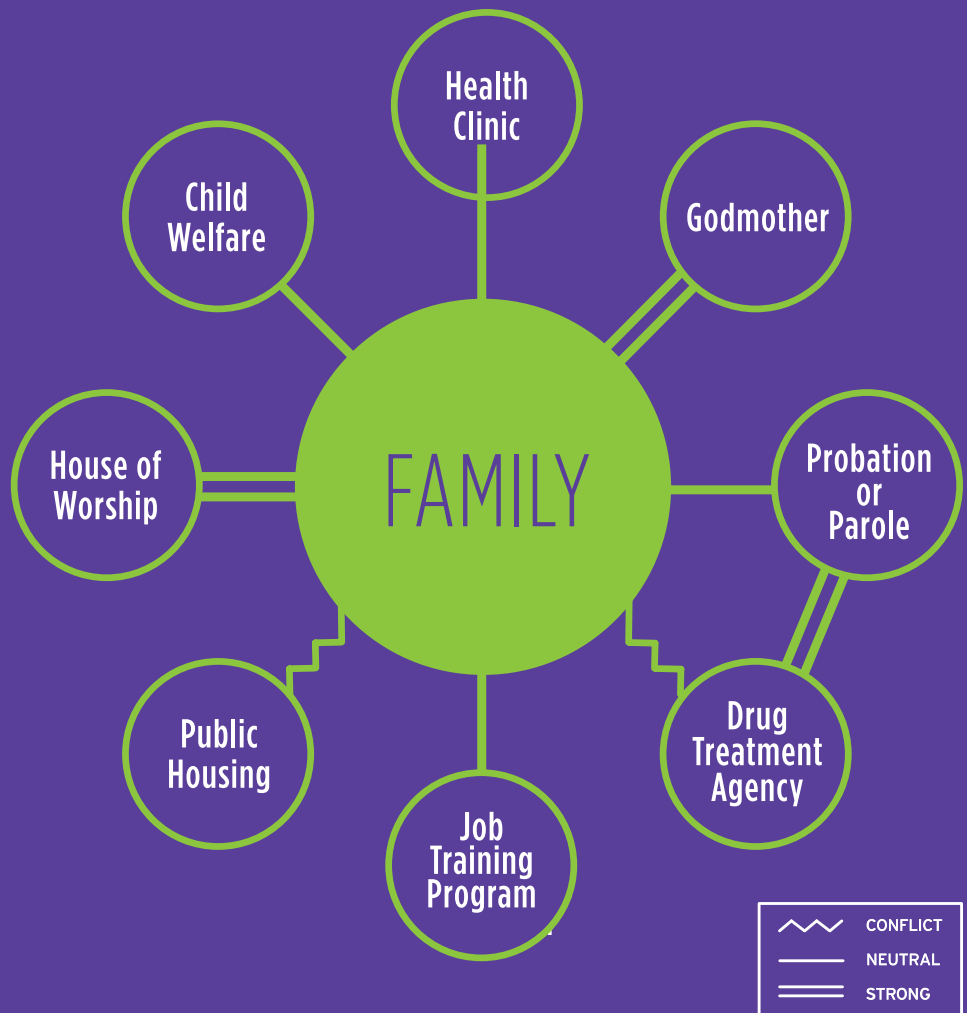

Supportive Inquiry helps identify family strengths, productive behaviors, and successful coping mechanisms. It allows you to gather more comprehensive information by relying on nonjudgmental open-ended questions that emphasize a family's capabilities.

The Interrelational Database uses the family as the unit of analysis. It can help your organization and a broad range of users to tap the strengths of families involved in the criminal justice system or juvenile justice system; track relationships and not just issues; and monitor the interactions and outcomes of entire families in various domains, such as school, work, health, and housing.

An **INSTITUTIONAL ECOMAP** displays the public and community resources an agency uses, including formal and informal organizations. This tool can help your agency incorporate a strength-based, family-focused approach by improving the way you do your work.



Organizations also find the Bodega Model's tools useful in activities beyond case management; the tools assist government agencies, nongovernmental organizations, and policy makers at various levels of their work in criminal justice, juvenile justice, public health, and related fields.

Family Justice's Relational Inquiry Tool is a complement to standard risk and needs assessments for people who are incarcerated. Not only can the tool build rapport and gather valuable information for case management, it can also serve as a starting point for your organization to focus on families and social networks. Using the instrument's questions, in a format familiar to people who complete assessments as part of their work, can be an important step toward better reentry outcomes.

YOU'RE IN GOOD COMPANY.

Through its far-reaching partnerships and alliances across the country, Family Justice is creating new pathways for sustainable social change. Bodega Model principles can be applied in diverse contexts. Family Justice's work with the Navajo Nation looks different from its work with the Chicago Housing Authority—and would look different with your organization as well.

Just as every family sets specific goals, each state, locality, or organization develops its own plan for change. Family Justice doesn't use a cookie-cutter approach, but instead draws on its tools and methods as well as your organization's expertise to create the most valuable and efficient initiative. You know the culture and context of your clients or participants; Family Justice's approach relies on that knowledge to help you come up with a plan that works.

- ¹ Sullivan, E., Mino, M., Nelson, K., & Pope, J. (2002). *Families as a Resource in Recovery from Drug Abuse: An Evaluation of La Bodega de la Familia*. New York: Vera Institute of Justice.
- ² Holt, N., & Miller, D. (1972). *Explorations in Inmate-Family Relationships*. Sacramento: California Department of Corrections, Research Division.
- ³ La Vigne, N. G., Visher, C., & Castro, J. (2004). *Chicago Prisoners' Experiences Returning Home*. Washington, DC: Urban Institute Justice Policy Center.
- ⁴ Visher, C., La Vigne, N. G., & Travis, J. (2004). *Returning Home: Understanding the Challenges of Prisoner Reentry*. Washington, DC: Urban Institute Justice Policy Center.
- ⁵ See Sullivan et al. (2002).

Designed by Jessica Weber Design, Inc. www.jwdnyc.com

Printed by Monroe Litho, a Forest Stewardship Council–certified printer using 100% renewable, nonpolluting wind power.

For information on integrating a family-focused approach into your work, please complete this form and mail it to the address below. If you prefer, feel free to call us at 212-475-1500 or e-mail us at info@familyjustice.org.

Name

Title

Organization

Address

City

State

Zip

E-mail

Phone



625 Broadway, 8th Floor, New York, New York 10012
T 212.475.1500 F 212.475.2322 www.familyjustice.org

FAMILIES ARE PART OF THE SOLUTION